



LIPPERT COMPONENTS

**SOFA SLIDEOUT SYSTEM
OPERATION AND SERVICE MANUAL**

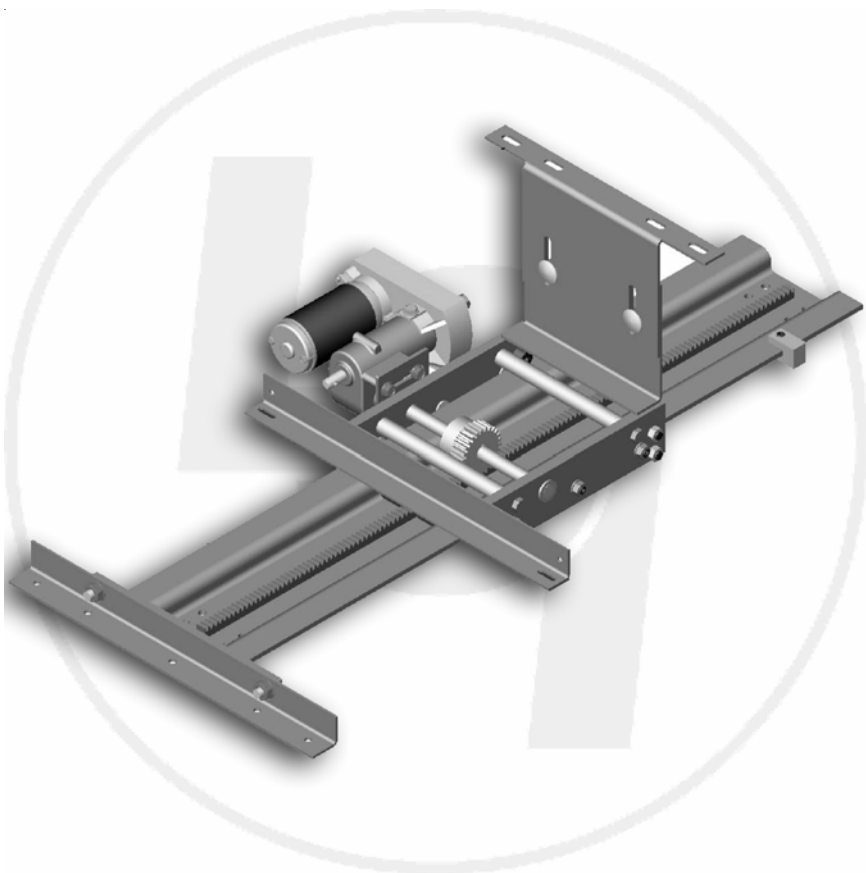



TABLE OF CONTENTS

SYSTEM.....	3
Warning.....	3
Description.....	3
Prior to Operation.....	4
OPERATION.....	5
Main Components.....	5
Mechanical.....	5
Electrical.....	6
Operating System.....	7
Extending Slideout Room.....	7
Retracting Slideout Room.....	7
Manual Operation.....	8
Preventative Maintenance.....	11
Electrical Maintenance.....	11
Mechanical Maintenance.....	12
SERVICE.....	13
Troubleshooting.....	13
Chart.....	14
Power Unit.....	15
Wiring Diagram.....	16
Ordering Parts.....	17
WARRANTY.....	18

SYSTEM

WARNING

FAILURE TO ACT IN ACCORDANCE WITH THE FOLLOWING MAY RESULT IN SERIOUS PERSONAL INJURY OR DEATH.

The *Lippert Sofa Slideout System* is intended for the sole purpose of extending and retracting the slideout room. It's function should not be used for any other purpose or reason and to actuate the slideout room. To use the system for any reason other than what it is designed for may result in damage to the coach and/or cause serious injury or even death.

Before actuating the system, please keep these things in mind:

- 1. Parking locations should be clear of obstructions that may cause damage when the slideout room is actuated.**
- 2. Be sure all persons are clear of the coach prior to the slideout room actuation.**
- 3. Keep hands and other body parts away from slideout mechanisms during actuation. Severe injury or death may result.**
- 4. To optimize slideout actuation, park coach on solid and level ground.**

DESCRIPTION

The *Lippert Sofa Slideout System* is a rack and pinion style slide system. Utilizing a bi-directional electric motor to actuate the drive shaft, the slideout room is extended and retracted from the same source. The actuator has a built-in automatic clutching feature. The *Lippert Sofa Slideout System* is designed as a negative or positive ground system.

There are no serviceable parts within the electric motor. If the motor fails, it must be replaced.

Disassembly of the motor voids the warranty.

Mechanical portions of the slideout system are replaceable. Contact Lippert Components, Inc. to obtain replacement parts.

PRIOR TO OPERATION

Prior to operating the *Lippert Sofa Slideout System*, follow these four (4) guidelines:

1. Coach should be parked on the most level surface available.
2. The **PARKING BRAKE** must be engaged.
3. The coach's transmission must be in **NEUTRAL** or **PARK**.
4. The coach's ignition must be in the **RUN** position or the coach's engine must be running. (Class A and C only)

OPERATION

MAIN COMPONENTS

MECHANICAL

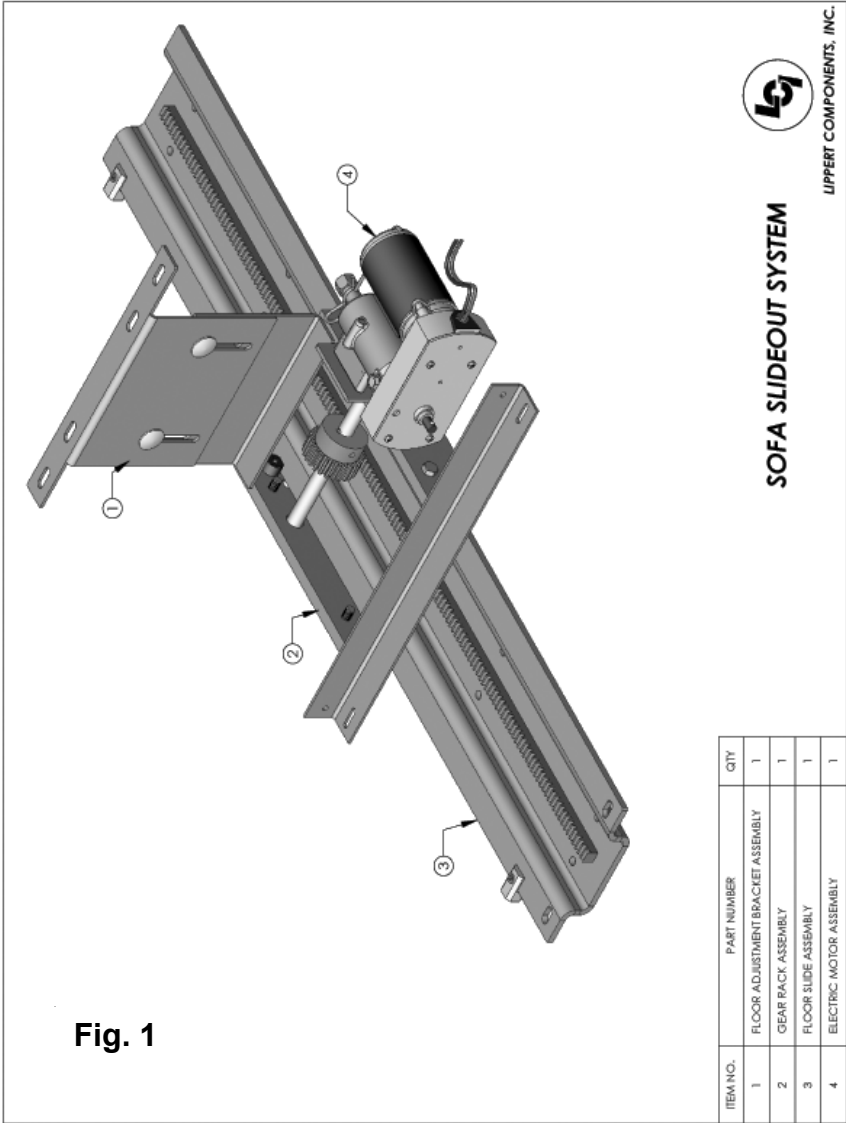

SOFA SLIDEOUT SYSTEM

LIPPERT COMPONENTS, INC.

ITEM NO.	PART NUMBER	QTY
1	FLOOR ADJUSTMENT BRACKET ASSEMBLY	1
2	GEAR RACK ASSEMBLY	1
3	FLOOR SLIDE ASSEMBLY	1
4	ELECTRIC MOTOR ASSEMBLY	1

ELECTRICAL

Power Unit – Motor and Gearbox Assembly

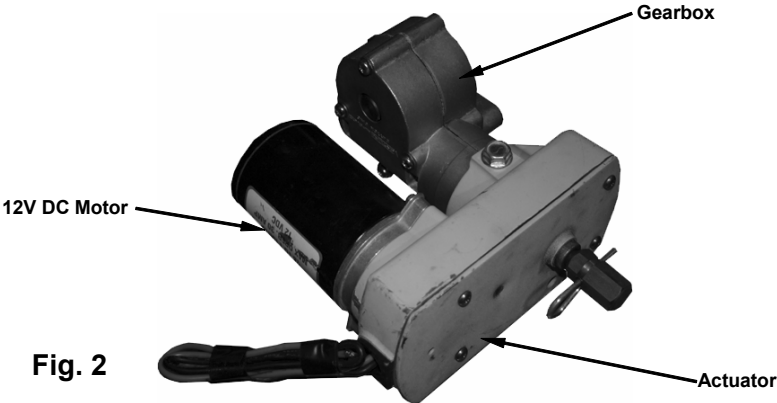

Wall Switch

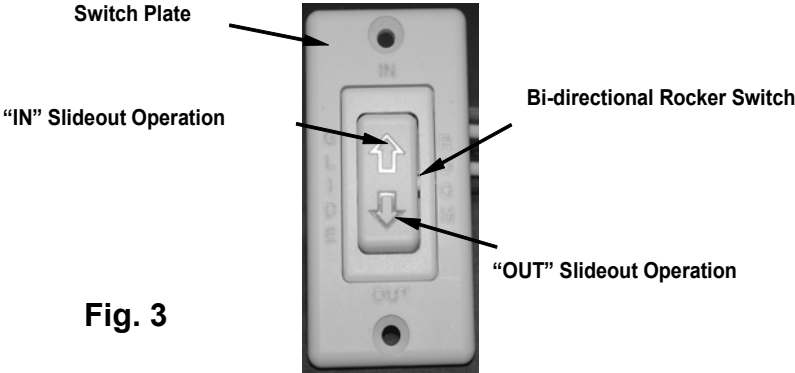

Circuit Breaker – Supplied by OE

OPERATING SYSTEM

WARNING

FAILURE TO ACT IN ACCORDANCE WITH THE FOLLOWING MAY RESULT IN SERIOUS PERSONAL INJURY OR DEATH.

ALWAYS MAKE SURE THAT THE SLIDEOUT ROOM PATH IS CLEAR OF PEOPLE AND OBJECTS BEFORE AND DURING OPERATION OF THE SLIDEOUT ROOM.

ALWAYS KEEP AWAY FROM THE SLIDE RAILS WHEN THE ROOM IS BEING OPERATED. THE GEAR ASSEMBLY MAY PINCH OR CATCH ON LOOSE CLOTHING CAUSING PERSONAL INJURY.

INSTALL TRANSIT BARS (IF SO EQUIPPED) ON THE SLIDEOUT ROOM DURING STORAGE AND TRANSPORTATION.

THE FAMILY OF *LIPPERT SOFA SLIDE SYSTEMS* IS CONTROLLED BY A SWITCH MOUNTED ON THE COACH WALL, NORMALLY LOCATED CLOSE TO THE ENTRY DOOR.

EXTENDING SLIDEOUT ROOM

1. Level the unit.
2. Verify the battery is fully charged and hooked-up to the electrical system.
3. Remove the transit bars (if so equipped).
4. Press and hold the IN/OUT switch (Fig. 5-B) in the OUT position until the room is fully extended and stops moving.
6. Release the switch, which will lock the room into position.

Note: If the slideout switch is held after the room in fully extended, the control will sense that the room has stopped and will shut off the motor after a few seconds.

RETRACTING SLIDE-OUT ROOM

1. Verify the battery is fully charged and hooked-up to the electrical system.
2. Press and hold the IN/OUT switch (Fig. 5-C) in the IN position until the room is fully retracted and stops moving.
3. Release the switch, which will lock the room into position.
NOTE: If the slideout switch is held after the room in fully retracted, the control will sense that the room has stopped and will shut off the motor after a few seconds.
4. Install the transit bars (if so equipped).

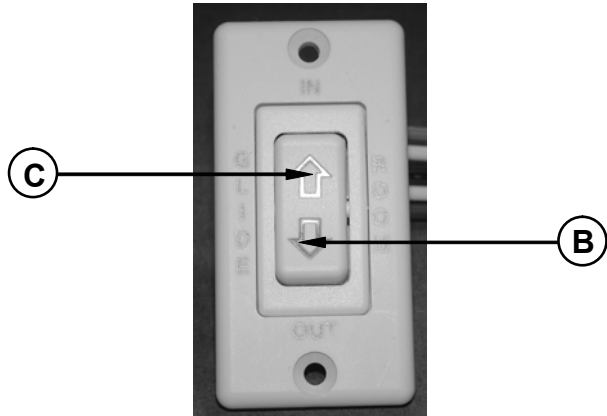

Fig. 5 - Slideout Switch and Switch Plate

MANUAL OPERATION

The ABF-24-711-18:1 is equipped with a backup auxiliary power (BAP) system that allows you to extend or retract a room if the rooms do not move when switch is pushed.

Check the troubleshooting guide on pages 10-13 for possible solutions before using the backup auxiliary system.



Fig. 6

1. Locate coach's house battery and disconnect the leads.
2. Access the slideout mechanism.

Note: This is an above floor style slideout. The motor and slideout mechanism is located inside the coach.

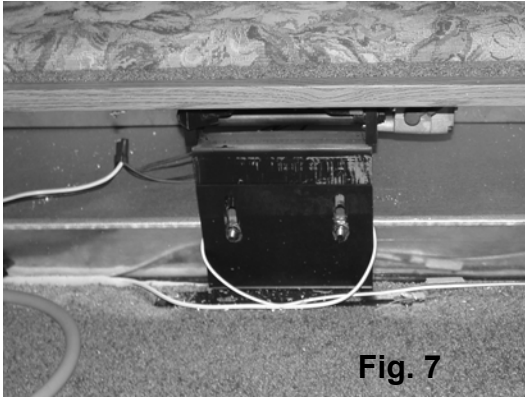

3. Disconnect the motor wire.

Note: Only one lead needs to be disconnected.

CAUTION – If neither lead is disconnected from battery, actuating the system may push an electrical charge back through the motor and damage the motor or other electrical components.

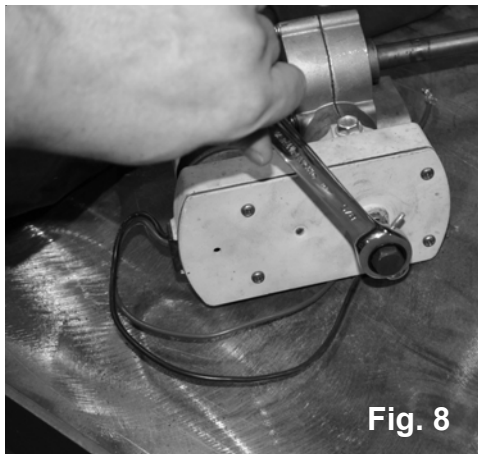

4. Using a 5/8 in wrench or socket/ratchet combination, rotate the shaft in the counterclockwise to retract slideout room.



5. Using a 5/8 in wrench or socket/ratchet combination, rotate the shaft in the clockwise to extend slideout room.

Note - Once the room has reached its fully extended/retracted position, apply pressure to the wrench to firmly set the room. The worm gear in the gear box will prevent the room from drifting in or out.

PREVENTATIVE MAINTENANCE

The *Lippert Sofa Slideout System* has been designed to require very little maintenance and has been static tested to over 2,500 continuous cycles with out any noticeable wear to rotating or sliding parts. No grease or lubrication is necessary and in some situations may be detrimental to the environment and long term dependability of the system. To ensure the long life of your slideout system, read and follow these few simple procedures.

ELECTRICAL SYSTEM MAINTENANCE

For optimum performance, slide-out system requires full battery current and voltage. The battery must be maintained at full capacity. Other than good battery maintenance, check the terminals and other connections at the battery, the control switch, and the electric motor for corrosion, and loose or damaged terminals. Check motor leads under the motorhome chassis. Since these connections are subject to damage from road debris, be sure they are in good condition.

Note: The *Lippert Sofa Slideout System* is designed to operate as a negative ground system. A negative ground system utilizes the chassis frame as a ground and an independent ground wire back to battery is necessary (see page 12 for wiring diagram). It is important that the electrical components have good wire to chassis contact. Over 90% of unit electrical problems are due to bad ground connections.

MECHANICAL MAINTENANCE

Although the system is designed to be almost maintenance free, inspect the slideout for any visible signs of external damage after and before movement of the room. Remember to inspect inside the coach as well as the slideout system outside the coach.

Note: For long-term storage: It is recommended that the room be closed (retracted).

- When the room is out, visually inspect the Slide Floor and Drive Box Assemblies. Refer to Fig. 1 for location of rail assemblies. Check for excess build-up of dirt or other foreign material; remove any debris that may be present.
- If the system squeaks or makes any noises it is permissible to apply a coat of lightweight oil to the drive shaft and roller areas but remove any excess oil so dirt and debris do not build-up. **DO NOT** use grease.

WARNING

**DO NOT WORK ON YOUR SLIDEOUT SYSTEM UNLESS THE BATTERY IS DISCONNECTED.
FAILURE TO ACT IN ACCORDANCE WITH THE FOLLOWING MAY RESULT IN SERIOUS PERSONAL INJURY OR DEATH.**

SERVICE

TROUBLESHOOTING

The *Lippert Sofa Slideout System* is only one of four inter-related slideout soom system components. These four components are as follows: chassis, slideout room coach and *Lippert Sofa Slideout System*. Each one needs to function correctly with the others or misalignment problems will occur.

Every coach has it's own personality and what may work to fix one coach may not work on another even if the symptoms appear to be the same.

When something restricts room travel, system performances will be unpredictable. It is very important that slide rails, inner and outer, be free of contamination and allowed to travel freely the full distance or "STROKE." Ice or mud build-up during travel is an example of some types of contamination that may occur.

When beginning to troubleshoot the system, make sure the battery is fully charged, there is no visible signs of external damage to the actuator, motor or rails and that the motor is wired properly and all connections are secure.

You can adjust room extension by modifying the position of the rack gear on the slide floor rail to the spur gear on the gear assembly.

During troubleshooting, remember, by changing, altering or adjusting one thing, it may affect something else. Be sure any changes do not create a new problem.

Additional information on the *Lippert Sofa Slideout System* by calling 866-524-7821 and asking for technical assistance.

IF YOU HAVE ANY PROBLEMS OR QUESTIONS CONSULT YOUR
LOCAL AUTHORIZED DEALER OR CALL LIPPERT AT:

(866) 524-7821.

TROUBLESHOOTING CHART

The following troubleshooting chart outlines some common problems, their causes and possible corrective actions. When reference is made to a "Power Unit," the term includes the motor and the actuator as a complete unit. All Power Units are shipped from the factory with a serial number and date code, which should be given to the service technician when asking for assistance.

ROOM DOESN'T MOVE WHEN SWITCH IS PRESSED	
PROBABLE CAUSE	CORRECTIVE ACTION
Restriction or obstruction inside or outside of unit	Check for and clear obstruction
Low battery voltage, blown fuse, defective wiring	Check battery voltage and charge if needed Find and check fuse, replace if blown. Check battery terminals and wiring. Look for loose disconnected or corroded connectors.
Excessive room drag	Check that transit bars are removed
POWER UNIT RUNS, ROOM DOES NOT MOVE	
Motor turns, room does not move	Gear key is broken or lost, replace gear drive assembly
Broken gear on drive shaft	Replace gear drive assembly
Broken gear in gearbox	Replace motor/gearbox assembly
Bad motor or gearbox	Replace motor/gearbox assembly
POWER UNIT RUNS, ROOM MOVES SLOWLY	
Low battery, poor ground, extremely low temperature	Charge battery, check ground wire
Room in bind	Adjust to proper room setting
Incorrect height adjustment	Check for proper room height
ROOM STARTS TO MOVE AND STOPS	
Obstruction of room inside or outside	Check for and remove any obstruction
Dirt or corrosion build upon mechanism	Clean dirt or corrosion and coat LIGHTLY with oil
ROOM CHATTERS DURING OPERATION	
Teeth on gear drive broken or worn	Replace gear drive assembly
Teeth on inner rail broken or worn	Replace inner rail assembly

Notes:

If the slideout room will not retract there is a manual override that is located on the opposite side of the slideout room. A crank handle is provided with your unit. Once you have the room in the closed position take you unit to the closest dealer. See pages 9-11 for Manual Override Instructions.

Switch related problems:

- If room moves opposite from what the switch plate indicates, reverse the motor wires on the back of the switch (refer to the wiring diagram page 12). Wire size must be 10ga. Min.
- If a gear is stripped, the entire gearbox must be replaced.
- If the room does not seal fully, refer to page 11.

TROUBLESHOOTING – POWER UNIT

Before attempting to troubleshoot the PowerUnit, make sure an adequate power source is available. The unit batteries should be fully charged or the unit should be plugged into A/C service with batteries installed. Do not attempt to troubleshoot the Power Unit without assuring a full 12V DC charge

The following tests require only a DC voltmeter (or DC test light) and a jumper lead.

Step 1 - Attach voltmeter (or test light) leads to the negative and positive switch terminals on back of wall switch (See Fig. 11). Does the meter indicate 12V DC?

If **YES**, see **Step 2**; if **NO** see **Step 3**.

Step 2 - If **YES**, at the motor, check the incoming leads to 12V DC (if necessary, disconnect leads at wire splices). Does meter indicate 12V DC? If **YES**, Power Unit needs to be replaced. The motor is not field serviceable. **DO NOT ATTEMPT TO REPAIR**. If **NO**, Inspect all wires and connections between the wall switch and the motor. Repair connections as necessary. Recheck as in **Step 1**.

Step 3 - If **NO**, Inspect all connections between battery and switch. Inspect 30A Circuit Breaker (See Fig. 11). Recheck as above in **Step 1**.

Since there are no field serviceable parts in the motor of the Power Unit, electrical troubleshooting and service is limited to replacing only those components as previously outlined.

Thorough inspection of wiring and connections is the only other electrical service that can be performed.

WIRING DIAGRAM

Fig. 11

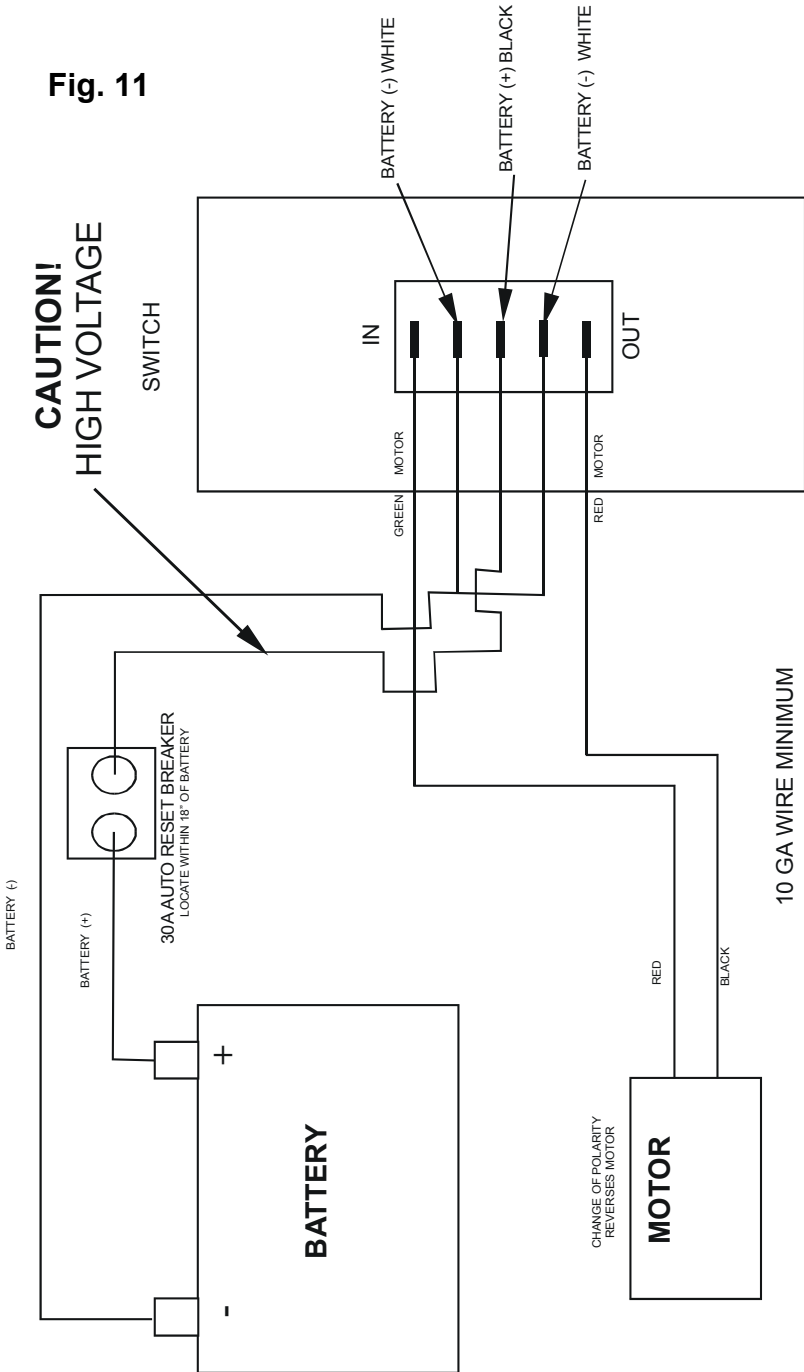

ORDERING PARTS

To assist the customer service when ordering parts, please provide the following information:

1. Your Name
2. Company Name
3. Phone Number
4. Shipping Address
5. Billing Address
6. Purchase Order Number
7. Coach
 - A. Serial # and/or VIN #
 - B. Make
 - C. Model
8. Part Number
9. Description
10. Quantity

Please take your coach to an authorized service center for repairs. Systems that have been modified, adjusted, repaired or augmented by a party other than an authorized service center may void any warranty claim with Lippert Components, Inc.

LIMITED WARRANTY

THIS WARRANTY EXTENDS ONLY TO THE MERCHANT/ORIGINAL PURCHASER ("Purchaser") ACQUIRING THE PRODUCT, AS DEFINED HEREIN, DIRECTLY FROM A LIPPERT COMPONENTS FACILITY AND SHALL NOT BE CONSTRUED TO EXTEND TO ANY THIRD PARTY, INCLUDING BUT NOT LIMITED TO THE CONSUMER OR ULTIMATE PURCHASER OF THE END PRODUCT. IN PART, THE PURPOSE OF THIS PROVISION IS TO REQUIRE THAT ANY AND ALL WARRANTY CLAIMS BE MADE BY THE MERCHANT/ORIGINAL PURCHASER, AND NOT BY A CONSUMER. THIS WARRANTY SUPERCEDES ANDY AND ALL PRIOR WARRANTIES.

LIPPERT COMPONENTS warrants the components of it's Recreational Vehicle Slide-Out System ("Product") against defects in materials and workmanship for the following time periods, beginning on the date of Retail Sale, so long as the Retail Sale occurs within six (6) months of the date Purchaser acquires the Product directly from a Lippert Components facility:

Three (3) Years – Any ball screw actuator, inner and out tube assembly, rack and gear assembly, electric motor and cross shaft.

Five (5) Years – Any fluid power components, limited to any hydraulic cylinder and hydraulic pump.

If a LIPPERT COMPONENTS Product is inspected by an authorized LIPPERT COMPONENTS representative and is determined to be defective in materials or workmanship within the aforementioned time period and pursuant to the requirements set forth herein, LIPPERT COMPONENTS will, in its sole and absolute discretion, do one of the following:

Repair or replace without charge FOB it's factory;

Send a service team to the then current location of the Product to repair or replace it on site; or allow credit for the Product.

All warranty claims MUST involve an inspection of the Product and be approved by an authorized LIPPERT COMPONENTS representative, and all repair procedures must be pre-approved by LIPPERT COMPONENTS before any repair work can begin. There are no exceptions to this procedure, so please contact your LIPPERT COMPONENTS division immediately before attempting any repairs or modifications on your LIPPERT COMPONENTS Product. No claim for Products alleged to be defective will be allowed until LCI has had a reasonable opportunity to investigate each claim.

This warranty does not cover customer instruction, installation or set up adjustments. Unless otherwise indicated by tangible evidence, LIPPERT COMPONENTS relies upon the engineering professionals of those that purchase its Products to design and specify a Product of sufficient size, dimension, strength and durability to support the structure the Purchaser intends to place upon the Product, and to design and specify a Product that is sufficient and adequate to function in the role the Purchaser intends to use and/or produced by its Purchasers and builds Products pursuant to those design specifications.

This warranty does not cover abuse, misuse or neglect, but is not limited to, improper usage, overloading, accident related damage, improper loading or incorrect weight bias loading, damage resulting from improper operation or maintenance, connection to improper towing unit or attempted repair by anyone other than an authorized representative of LIPPERT COMPONENTS. This warranty does not cover cosmetic damage, damage due to acts of God, commercial use or modification of the Product, or Products sold AS IS and/or WITH ALL FAULTS. This warranty is valid only in the United States and Canada.

EXCEPT TO THE EXTENT PROHIBITED BY APPLICABLE LAW, ANY IMPLIED WARRANTIES OF MERCHANTABILITY OR FITNESS FOR A PARTICULAR PURPOSE ARE HEREBY DISCLAIMED. REPAIR, REPLACEMENT OR CREDIT AS PROVIDED UNDER THIS WARRANTY IS THE EXCLUSIVE REMEDY OF THE PURCHASER. IN NO EVENT WILL LIPPERT COMPONENTS BE LIABLE FOR INCIDENTAL OR CONSEQUENTIAL DAMAGES.

Claims – All claims are barred unless reported in writing by Purchaser to LIPPERT COMPONENTS, with full particulars, promptly after the damage was or reasonably should have been discovered and full facilities are offered LIPPERT COMPONENTS for inspection and investigation. LIPPERT COMPONENTS will not consider any claims for material that is not in the original form.

All written notices required by this warranty shall be sent to:

Lippert Components, Inc.
Attn: Risk Management Department
2375 Tamiami Trail N., Suite 1101
Naples, FL 34103

This warranty is invalid if factory applied identification criteria have been altered or removed from the Product.

Work performed by others must have the prior authorization of LIPPERT COMPONENTS to be honored.

Third-Party Events – In the event of any accident, injury to person, damage to property, loss or other occurrence involving a LIPPERT COMPONENTS Product, Purchaser shall notify LIPPERT COMPONENTS of such event within thirty (30) days of the event or within ten (10) days of the notification to Purchaser, whichever is earlier. Notwithstanding the foregoing, Purchaser shall notify LIPPERT COMPONENTS **immediately** upon learning that a survey, test or inspection is to be made with respect to the LIPPERT COMPONENTS Product and provide LIPPERT COMPONENTS with the opportunity to participate in any such survey, test or inspection, or to permit LIPPERT COMPONENTS to conduct its own survey, test or inspection. Failure to comply with each of the foregoing shall bar any claim by the Purchaser against LIPPERT COMPONENTS concerning any such event and shall require Purchaser to defend, indemnify and hold LIPPERT COMPONENTS harmless from all claims asserted against LIPPERT COMPONENTS concerning any liability of LIPPERT COMPONENTS arising out of such event.

Severability – Any legally or otherwise invalid provision hereof shall be considered severable.

Any conditions or exceptions which may be stated in any communication or document received by LIPPERT COMPONENTS from any entity or individual, including but not limited to the Purchaser, shall be of no effect unless specifically agreed to in writing by LIPPERT COMPONENTS.

The current warranties and terms outlined on LIPPERT COMPONENTS' website (www.lippertcomponents.com) on the date of the purchase shall take precedence over any other warranties whether verbal or written. LIPPERT COMPONENTS reserves the right to alter its warranties from time to time, as the laws and the company's business needs and industry change.

TO THE GREATEST EXTENT PERMITTED BY LAW, ANY CONTROVERSY OR CLAIM ARISING OUT OF OR IN RELATIONS TO THIS WARRANTY SHALL BE DETERMINED BY BINDING ARBITRATION IN NAPLES, FLORIDA (COLLIER COUNTY) IN ACCORDANCE WITH THE COMMERCIAL ARBITRATION RULES OF THE AMERICAN ARBITRATION ASSOCIATION. PURCHASE OF THE PRODUCT CONSTITUTES PURCHASER'S AGREEMENT TO THIS PROVISION.

Lippert Components, Inc.
Warranty Registration Card

Attention Purchaser: Please fill out form as completely as possible, detach at the dashed line above and mail this card to Lippert Components, Inc. at the following address within 30 days of the date of retail purchase of your unit to activate your warranty on this product.

Lippert Components, Inc. – Plant #39
Attn: Service and Warranty
2616 Caragana Ct.
Goshen, IN 46526

RV Description _____ (Manufacturer) _____ (Model) _____ (Year)

_____ (VIN Number) _____ (Number of Slides)

Check all that apply: Lippert Electric Slide-outs Lippert Hydraulic Slideouts Lippert Hydraulic Leveling

Owner Name _____

Address _____

Phone _____